

AD60

Underground Articulated Truck Preliminary



Engine

Engine Model	Cat® C27 ACERT™	
Gross Power – SAE J1995 (1st gear/2-7th gear)	579/600 kW	776/805 hp
Net Power – SAE J1349 (1st gear/2-7th gear)	540/560 kW	725/751 hp

Operating Specifications

Nominal Payload Capacity	60 000 kg	132,277 lb
Gross Machine Operating Weight	110 000 kg	242,508 lb

AD60 Features

One Supplier

Caterpillar designed and manufactured major power and drive train components for reliability and performance.

High Performance Engine

The Cat® C27 engine with ACERT™ Technology offer the perfect balance between power, robust design and economy.

Power Shift Transmission

Reliable and rugged design to deliver power and efficiency for peak power train performance.

Engine/Power Train Integration

Intelligent and robust electronics integrate all power and drive train components for overall optimum performance.

Robust Braking

Cat oil-cooled multiple disc brakes offer exceptional, fade resistant braking in all haul road conditions.

Comfortable Cab

Ergonomically designed for all-day comfort, control and productivity.

Truck Body

A variety of Caterpillar designed and built bodies and liners ensure optimal performance and reliability in tough mining applications.

Enhanced Serviceability

Designed with improved service points and grouped service locations to simplify maintenance and repair.

Contents

Power Train – Engine	4
Power Train – Transmission	5
Engine/Power Train Integration.....	6
Cat Brake System.....	7
Operator Comfort	8
Truck Body Systems	9
Structures.....	10
Serviceability	10
Customer Support.....	11
Safety	12
Specifications.....	13
Standard Equipment.....	18
Optional Equipment.....	19





The AD60 Underground Articulated Truck is designed for high production, low cost-per-ton hauling in underground mining applications. Rugged construction and simplified maintenance guarantee long life with low operating costs.

Engineered for performance, designed for comfort, built to last.

Power Train – Engine

The Cat C27 engine is built for power, reliability and efficiency.

ACERT Technology

The Cat C27 is U.S. EPA Tier 2 and EU Stage II compliant. It delivers higher power and greater durability for maximum hauling performance in the most demanding mining applications. Complete system integration of the engine and transmission optimizes performance and efficiency.

Power Increase

The 21.8% power increase over previous models provides unequalled lugging force during acceleration and less down-shifting on grade. Improved software and updates in engine technology further improve transmission shifting and decrease fuel consumption.

Watercooled Turbocharged and ATAAC

Air-to-air aftercooling provides improved fuel economy by packing cooler, denser air into cylinders for more complete combustion of fuel and lower emissions.

Electronic Unit Injection (EUI)

The electronically controlled unit injection fuel system senses operating conditions and regulates fuel delivery for optimum fuel efficiency. The proven high-pressure fuel system provides improved response times and more efficient fuel burn with lower emissions and less smoke.

Electronic Control Module (ECM)

ECM utilizes advanced engine management software to monitor, control and protect the engine utilizing self-diagnosing electronic sensors. The computerized system senses operating conditions and power requirements and adjusts engine for peak performance and most efficient operation at all times.

Design

Caterpillar designed one-piece cast iron block provides maximum strength and durability. Two-piece articulated pistons with forged steel crowns are designed to withstand higher cylinder pressure.

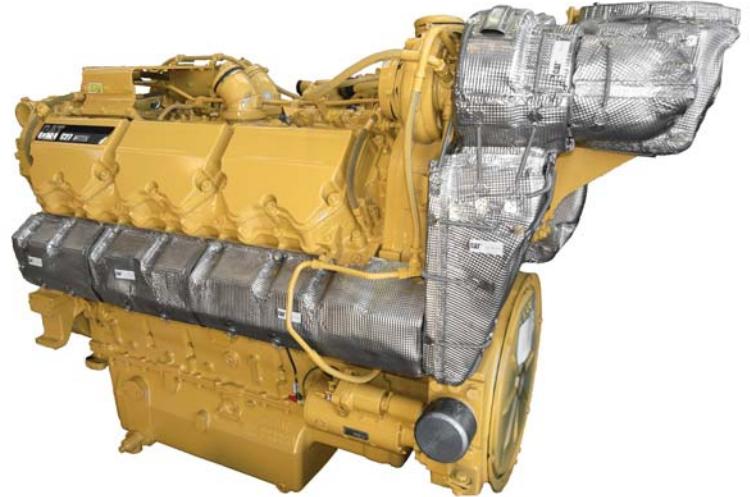

Power Train – Transmission

More power to the ground for greater productivity.

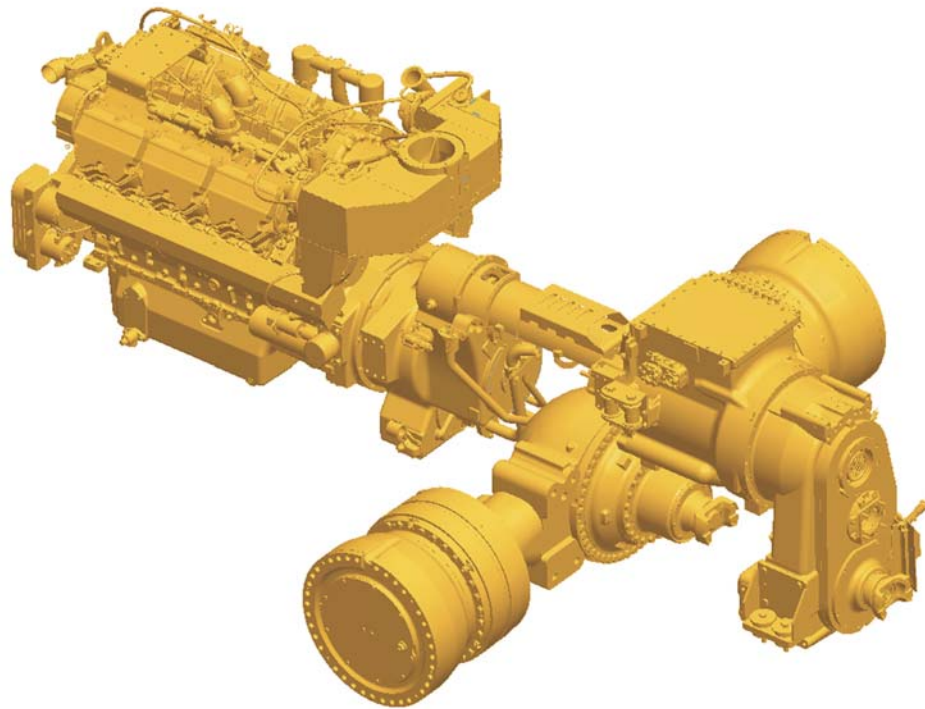

Mechanical Power Train

The Cat mechanical drive power train and power shift transmission provide unmatched operating efficiency and control on steep grades, in poor underfoot conditions, and on haul roads and drives with high rolling resistance.

Transmission

The Cat seven-speed planetary power shift transmission is matched with the direct-injection C27 engine with ACERT Technology to deliver constant power over a wide range of operating speeds. Individual clutch modulation provides smooth clutch engagements to optimize performance and extend clutch life.

Lock-Up Torque Converter

Combines maximum rimpull and cushioned shifting of torque converter drive with the efficiency and performance of direct drive. When engaged, lock-up provides superior power train efficiency by delivering more power to the wheels.

Lock-Up Clutch

Quickly releases and re-engages to reduce power train torque loads for smoother shifting, long life and a more comfortable ride.

Remote Transmission Oil Cooler

Increases cooling capacity in the transmission oil circuit to ensure optimal performance on long, uphill loaded hauls.

Engine/Power Train Integration

Intelligent electronics for overall optimal performance.

CAT MONITORING SYSTEM

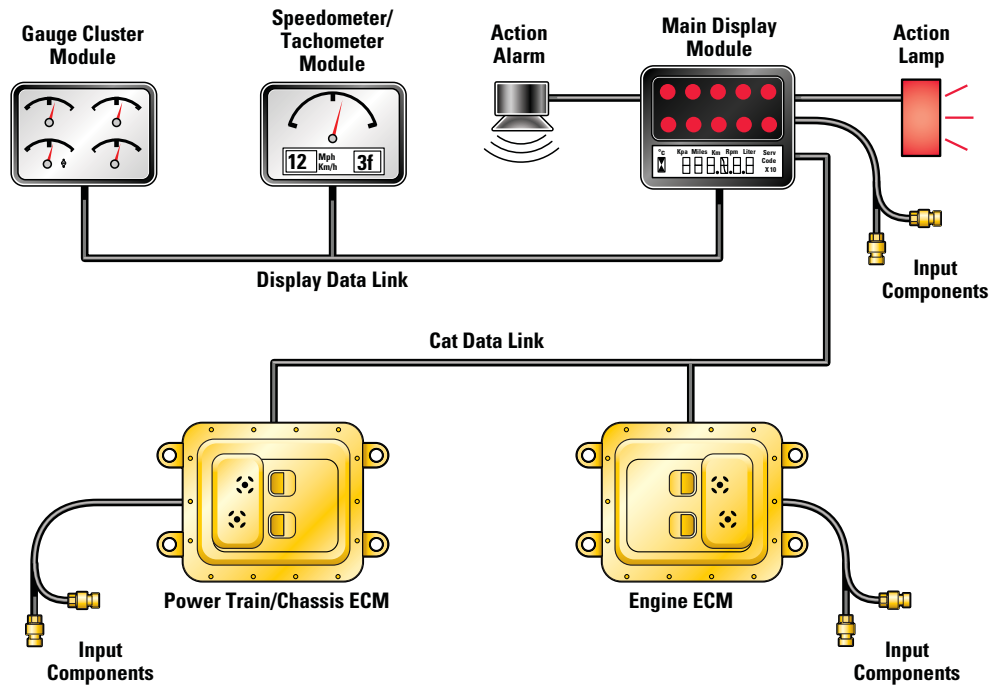

Cat Data Link

Electronically integrates machine computer systems to optimize overall power train performance, increase reliability and component life, and reduce operating costs.

- **Controlled Throttle Shifting** – Regulates engine RPM, torque converter lock-up and transmission clutch engagement for smoother shifts and longer component life.
- **Economy Shift Mode** – Decreases fuel consumption, lowers noise levels and potentially longer engine life.
- **Directional Shift Management** – Regulates engine speed to prevent damage caused by high speed directional changes.
- **Body-up Shift Inhibitor** – Prevents the transmission from shifting above a pre-programmed gear without the body fully lowered.

Electronic Technician (Cat ET)

Cat ET service tool provides service technicians with easy access to stored diagnostic data through Cat Data Link to simplify problem diagnosis and increase availability.

Overspeed Protection

The transmission control electronically senses engine conditions and automatically up-shifts to prevent overspeeding.

Cat Brake System

Superior control for operator confidence.

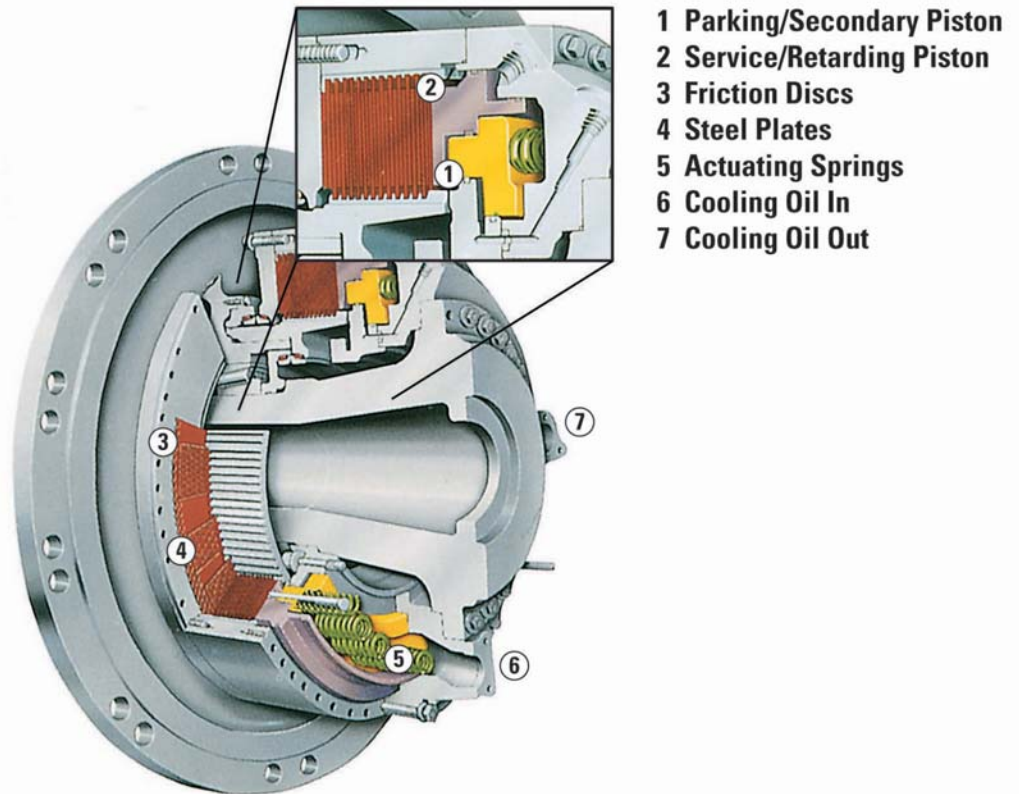

Integrated Braking System

The Cat oil-cooled braking system delivers reliable performance and control in the most extreme underground mining conditions. The integrated system combines the service, secondary, parking brake and retarding functions in the same robust system for optimum braking efficiency.

Oil-Cooled Multiple Disc Brakes

Four-wheel, forced oil-cooled, multiple disc service brakes are continuously cooled by a water-to-oil heat exchangers for non-fade braking and retarding performance. They are also completely enclosed to prevent contamination and reduce maintenance.

Automatic Retarder Control (ARC)

Electronically controls retarding on grade to maintain optimum engine RPM and oil cooling. Additional braking may be applied using the manual retarder or the brake pedal. ARC also allows the operator to maintain optimum engine speeds for faster downhill hauls and greater productivity. The ARC automatically activates when engine speed exceeds factory preset levels.

Superior Control

Automatic brake modulation offers a smoother ride and greater control, allowing the operator to concentrate on driving.

Operator Comfort

Ergonomically designed for all-day comfort, control and productivity.



The AD60 operator station is ergonomically designed for total machine control in a comfortable, productive and safe environment. All controls, levers, switches and gauges are positioned to maximize productivity and minimize operator fatigue.

Protective Structure

Integral to the cab and frame, both the Rollover Protective Structure (ROPS) and Falling Objects Protective Structure (FOPS) are resiliently mounted to the mainframe to isolate the operator from vibration for a more comfortable ride.

Standard Enclosed Cab

Standard sound-suppressed ROPS cab provides a quiet, secure and comfortable air-conditioned working environment with fresh, pressurized, temperature-controlled air circulation.

Cat Comfort Air Suspension Seat

Ergonomic, fully adjustable suspension seat provides optimal operator comfort. Designed to minimize vertical and lateral motion of the operator. Thick cushions reduce pressure on lower back and thighs. Wide, retractable seat belts provide a secure, comfortable restraint.

Steering Column

Comfort wheel with tilt steering provides a comfortable driving position, secure grip and greater control.

Monitoring System

Cat Electronic Monitoring System (Cat EMS) continuously provides critical machine data to keep the machine performing at top production levels. Displays are backlit for easy viewing.

Truck Body Systems

Rugged performance and reliability in tough underground mining applications.



Body Design

Cat truck bodies are designed for optimal strength, capacity, durability and low cost per ton.

Cat Truck Bodies

Caterpillar has two body styles to meet your application:

- Dump Body
- Ejector Body

The ejector body offers clean load ejection and can be easily removed and switched with a dump body for greater machine versatility.

Body Selection

Selection of the right body depends on material, haul road, and dump conditions. The better the match of body to application, the greater the efficiency. Its diverging flow design gives clean load ejection, which maximizes production and avoids material carryback.

Body/Chassis Integration

Cat truck bodies are designed and matched with the integrated chassis system for optimum structural reliability, durability and long life.

Fast Hoist Cycle Times

Single-stage hoist cylinders provide fast dump cycle times of 12 seconds for raise and 24 seconds for lower.

Truck Payload Management System (TPMS)

The standard TPMS system calculates the payload the truck is carrying and determines truck cycle times.



Structures

Rugged Cat structures – the backbone of the AD60's durability.

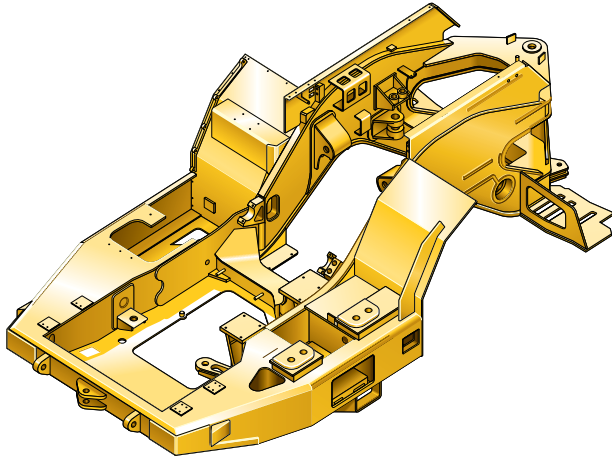

Frame Design

The frame uses box-section design with stiff frame beams to resist twisting forces giving it a longer structural life.

Articulating/Oscillating Hitch

This system provides steering and oscillation and enables the truck to maintain all wheel ground contact in rough terrain.

Serviceability

More time for production.

Ground-Level Service Access

Easy access to daily service points allows convenient servicing to tanks, filters, lubrication points, compartment drains and sight gauges for quick fluid level checks.

Diagnostics – Cat Electronic Technician

Electronic control system enables quick diagnosis of engine conditions and effective maintenance and repairs utilizing the Cat ET Service Tool.

VIMS Guardian 3rd Generation System

This standard technology enables your equipment to provide detailed, up-to-the-minute data about its own health and working conditions by monitoring key temperatures, pressures, and more. The system gathers historical trends, histograms, events and more for off-board analysis.

Sight Gauges

Makes fluid level checks quick and easy. These include the hydraulic, transmission and coolant reservoirs.



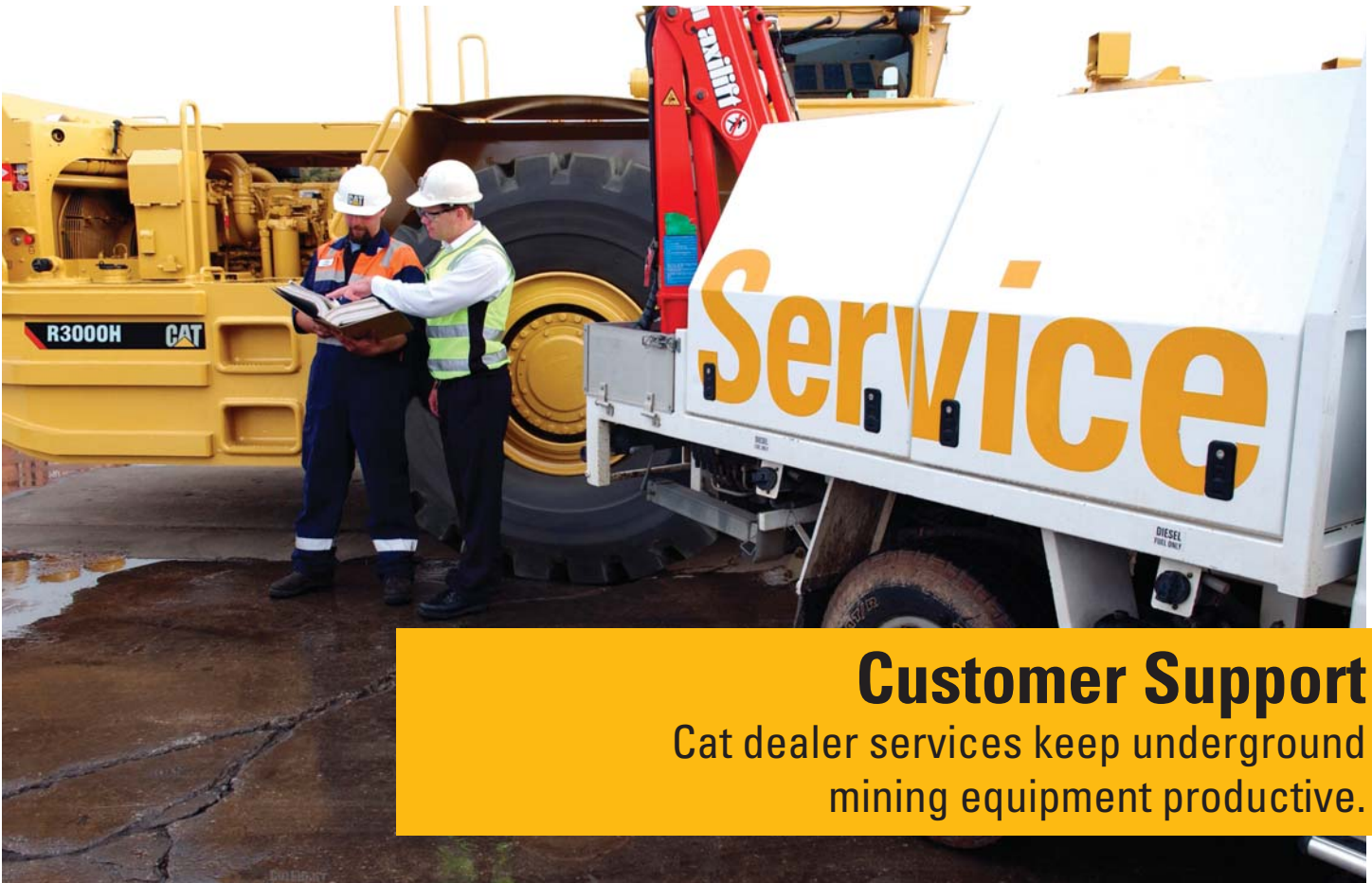

Customer Support

Cat dealer services keep underground mining equipment productive.

Dealer Capability

Cat dealers will provide the level of support you need, on a global scale. Dealer expert technicians have the knowledge, experience, training and tooling to handle your repair and maintenance needs. They offer 24/7 product support via a worldwide network of reliable and prompt parts distribution facilities, dealer service centers, and technical training facilities to keep your equipment up and running.

Service Support

Cat equipment is designed and built to provide maximum productivity and operating economy throughout its working life. Cat dealers offer a wide range of service plans that will maximize return on your investment, including:

- Preventive Maintenance Programs
- Diagnostic Programs, such as Scheduled Oil Sampling and Technical Analysis
- Rebuild and Reman Options
- Customer Support Agreements

Technology Products

Cat dealers offer a range of advanced technology products designed to improve efficiency, productivity and lower costs.

Operator Training

Your Cat dealer can arrange operator training to improve productivity, decrease downtime, reduce operating costs and enhance safety.

Safety

Designed with safety as the first priority.

Product Safety

Caterpillar has been and continues to be proactive in developing mining machines that meet or exceed safety standards. Safety is an integral part of all machine and systems designs.

Engine Shutoff Switch

A secondary engine shutoff switch is located at ground level.

Integral ROPS Cab

Integral to the cab and frame, the ROPS is resiliently mounted to the frame to isolate the operator from vibration for a more comfortable ride.

Brake Systems

Four corner oil-cooled braking system provides excellent control. The service brakes and retarding system are actuated by modulated hydraulic pressure, while the parking brake function is spring applied and hydraulic released. This system assures braking in the event of loss of hydraulic pressure.

Operator Present System

Automatically engages parking brake, neutralizes steering, implement and transmission control, and shuts down the engine in the event the operator fails to apply the park brake prior to exiting the cab.

Standard Safety Features

Anti-skid upper deck surfaces, upper deck handrails, 3-point cabin and machine access, push out safety glass, excellent visibility, suspension seat, passenger/training seat, inertia reel retractable belts, steering frame lock, rear window guard, body retaining pins, automatic retarder control, exhaust heat shielding and firewall fitted standard, hitch hydraulic hoses – burst protection sleeves fitted, tailgate retaining pins (ejector body), alternate exit via windows, ground level compartment sight glasses, hot and cold side of engine.

SAFETY.CAT.COM™

For more complete information on safety, please visit <http://safety.cat.com>.



AD60 Underground Articulated Truck Specifications

Engine

Engine Model	Cat C27 ACERT	
Rated Power	2,000 rpm	
Gross Power – SAE J1995 (1st gear/2-7th gear)	579/600 kW	776/805 hp
Net Power – SAE J1349 (1st gear/2-7th gear)	540/560 kW	725/751 hp
Net Power – ISO 9249	540/560 kW	725/751 hp
Net Power – 80/1269/EEC	540/560 kW	725/751 hp
Bore	137.2 mm	5.4 in
Stroke	152.4 mm	6 in
Displacement	27 L	1,648 in ³

- Power ratings apply at a rated speed of 2,000 rpm when tested under the reference conditions for the specified standard.
- Ratings based on SAE J1995 standard air conditions of 25° C (77° F) and 100 kPa (29.61 Hg) barometer. Power based on fuel having API gravity of 35 at 16° C (60° F) and an LHV of 42 780 kJ/kg (18,390 BTU/lb) when engine used at 30° C (86° F).
- Engine derate will commence at an altitude of 557 m (1,827 ft).
- Compliant with U.S. Environmental Protection Agency Tier 2 emission standards.

Operating Specifications

Nominal Payload Capacity	60 000 kg	132,277 lb
Gross Machine Operating Weight	110 000 kg	242,508 lb

Weights

Empty	49 969 kg	110,163 lb
Front Axle	34 279 kg	75,572 lb
Rear Axle	15 690 kg	34,591 lb
Loaded	110 000 kg	242,508 lb
Front Axle	55 440 kg	122,224 lb
Rear Axle	54 560 kg	120,284 lb

Weight Distribution

Empty		
Front Axle	68.6%	
Rear Axle	31.4%	
Loaded		
Front Axle	49.8%	
Rear Axle	50.2%	

Transmission

Forward 1	6.6 km/h	4.1 mph
Forward 2	9.3 km/h	5.8 mph
Forward 3	12.5 km/h	7.5 mph
Forward 4	16.8 km/h	10.4 mph
Forward 5	22.7 km/h	14.1 mph
Forward 6	30.7 km/h	19.1 mph
Forward 7	41.5 km/h	25.8 mph
Reverse 1	8.7 km/h	5.4 mph

- Maximum travel speeds with standard 35 × 65 R33 tires.

Final Drives

Differential Ratio	3.46:1
Final Drive Ratio	5.5:1
Total Reduction Ratio	19.04:1

Body Hoist

Raise	12 Seconds
Lower	24 Seconds
Total Cycle Time	36 Seconds

AD60 Underground Articulated Truck Specifications

Body Capacities

Dump Body – 1	26.9 m ³	35.2 yd ³
Dump Body – 2	32.6 m ³	42.6 yd ³
Dump Body – 3	33.8 m ³	44.2 yd ³
Dump Body – 4	36.6 m ³	47.9 yd ³
Ejector Body – 1	26.9 m ³	35.2 yd ³
Ejector Body – 2	29.4 m ³	38.5 yd ³

- Heaped SAE 2:1.

Turning Dimensions

Outside Clearance Radius	10 005 mm	393.9 in
Inside Turning Radius	5540 mm	218.1 in
Frame Oscillation	10°	
Articulation Angle	42.5°	

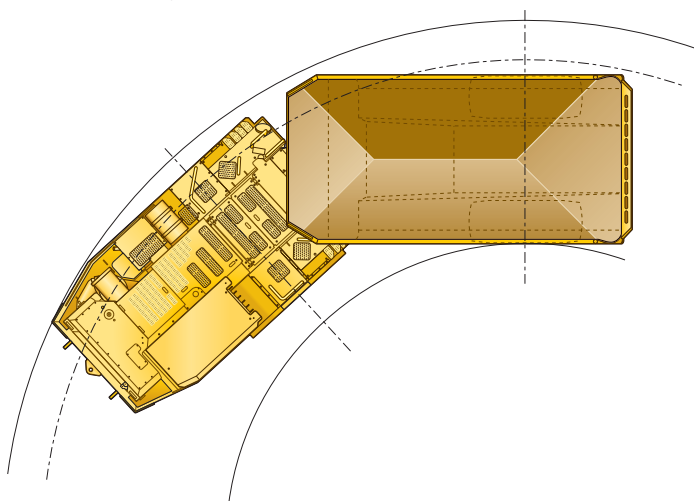

Service Refill Capacities

Engine Crankcase with Filter	99 L	26.2 gal
Transmission	53 L	14 gal
Hydraulic Tank	258 L	68.2 gal
Cooling System	138 L	36.5 gal
Front Differentials and Final Drives	138 L	36.5 gal
Rear Differentials and Final Drives	138 L	36.5 gal
Fuel Tank	940 L	248.3 gal

Tires

Tire Size	35 × 65 R33
-----------	-------------

Standards

Brakes	ISO 3450, AS2958.1, CAN-CSA424.30-M90
Cab/FOPS	ISO 3449, SAE J231, AS2294.3, EN13627
Cab/ROPS	ISO 3471, SAE J1040, AS2294.2, EN13510

Dimensions

All dimensions are approximate.

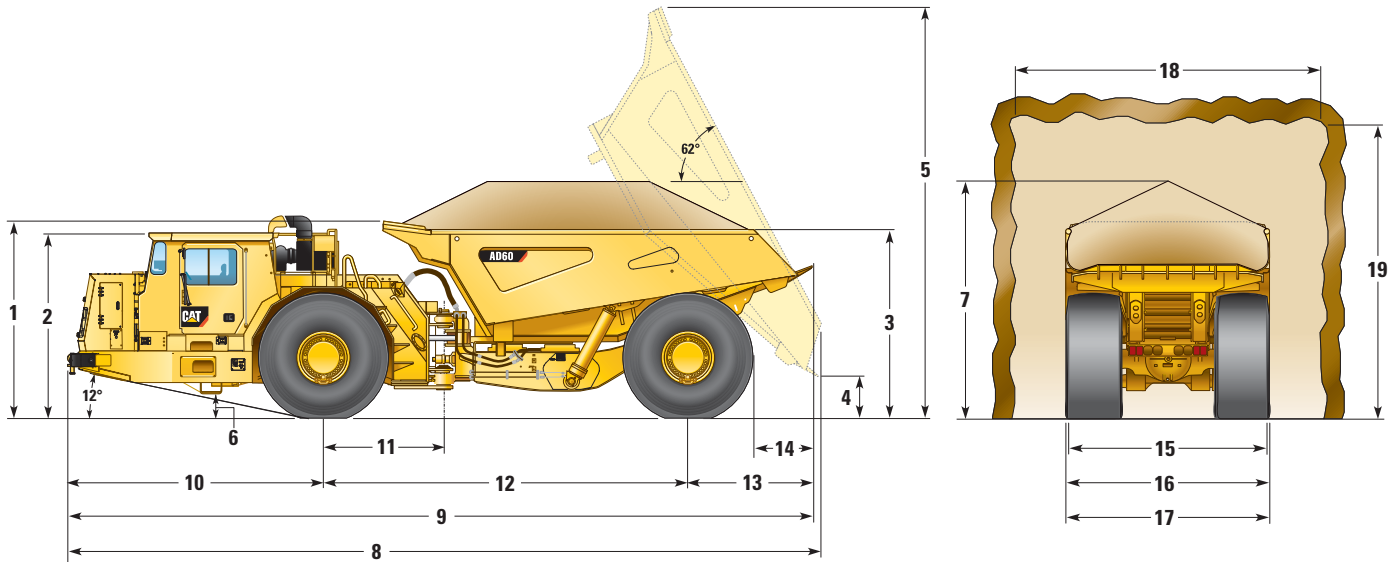

	370-2757		370-2758		370-2755		370-2756	
	Dump Body		Dump Body		Dump Body		Dump Body	
Body Capacity	26.9 m ³	35.2 yd ³	32.6 m ³	42.6 yd ³	33.8 m ³	44.2 yd ³	36.6 m ³	47.9 yd ³
	mm	in	mm	in	mm	in	mm	in
1 Height – Top of Empty Body	3202	126.1	3418	134.6	3556	140.0	3560	140.2
2 Height – Top of ROPS	3000	118.1	3000	118.1	3000	118.1	3000	118.1
3 Height – Body Loading	3045	119.9	3326	130.9	3426	134.9	3473	136.7
4 Height – Dump Clearance**	514	20.2	514	20.2	514	20.2	514	20.2
5 Height – Top of Raised Body	6969	274.4	7202	283.5	7322	288.3	7334	288.7
6 Height – Ground Clearance	393	15.5	393	15.5	393	15.5	393	15.5
7 Height – Top of Load (SAE 2:1)	3848	151.5	4178	164.5	4183	164.7	4333	170.6
8 Length – Maximum Body Raised	12 064	475.0	12 180	479.5	12 222	481.2	12 241	481.9
9 Length – Overall Body Down	12 040	474.0	12 040	474.0	12 040	474.0	12 040	474.0
10 Length – Front Axle to Front Bumper	4164	163.9	4164	163.9	4164	163.9	4164	163.9
11 Length – Front Axle to Hitch	1920	75.6	1920	75.6	1920	75.6	1920	75.6
12 Length – Wheel Base	5900	232.3	5900	232.3	5900	232.3	5900	232.3
13 Length – Rear Axle to Tail	1976	77.8	1976	77.8	1976	77.8	1976	77.8
14 Length – Rear Wheel to Raised Body	857	33.7	857	33.7	857	33.7	857	33.7
15 Width – Overall Tire	3250	128.0	3250	128.0	3250	128.0	3250	128.0
16 Width – Machine with Body	3346	131.7	3480	137.0	3480	137.0	3480	137.0
17 Width – Machine without Body	3346	131.7	3346	131.7	3346	131.7	3346	131.7
18 Recommended Clearance Width*	5000	196.9	5000	196.9	5000	196.9	5000	196.9
19 Recommended Clearance Height*	5000	196.9	5000	196.9	5000	196.9	5000	196.9

* Clearance dimensions are for reference only.

** Measurement taken with tailgate down for ejector body.

AD60 Underground Articulated Truck Specifications

Dimensions

All dimensions are approximate.

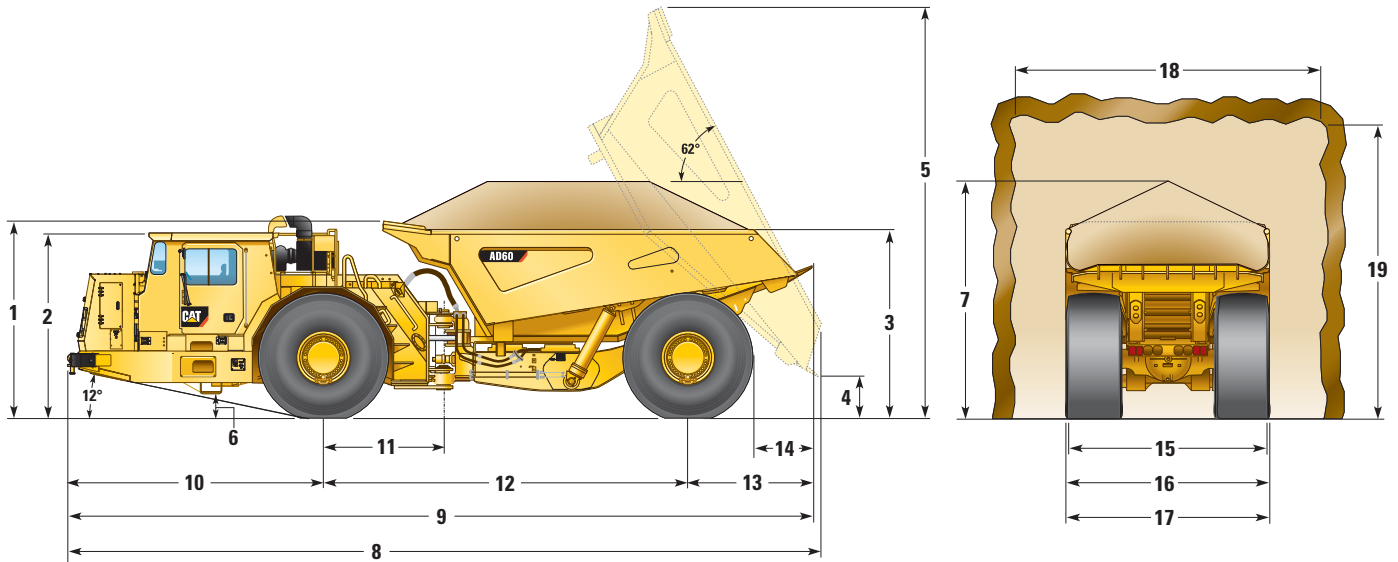

	370-2736		361-8561	
	Ejector Body		Ejector Body	
Body Capacity	26.9 m ³	35.2 yd ³	29.4 m ³	38.5 yd ³
	mm	in	mm	in
1 Height – Top of Empty Body	3436	135.3	3643	143.4
2 Height – Top of ROPS	3000	118.1	3000	118.1
3 Height – Body Loading	3255	128.1	3457	136.1
4 Height – Dump Clearance**	954	37.6	954	37.6
5 Height – Top of Raised Body	—	—	—	—
6 Height – Ground Clearance	393	15.5	393	15.5
7 Height – Top of Load (SAE 2:1)	4109	161.8	4284	168.7
8 Length – Maximum Body Raised	—	—	—	—
9 Length – Overall Body Down	12 125	477.4	12 125	477.4
10 Length – Front Axle to Front Bumper	4164	163.9	4164	163.9
11 Length – Front Axle to Hitch	1920	75.6	1920	75.6
12 Length – Wheel Base	5900	232.3	5900	232.3
13 Length – Rear Axle to Tail	2061	81.1	2061	81.1
14 Length – Rear Wheel to Raised Body	—	—	—	—
15 Width – Overall Tire	3250	128.0	3250	128.0
16 Width – Machine with Body	3560	140.2	3560	140.2
17 Width – Machine without Body	3346	131.7	3346	131.7
18 Recommended Clearance Width*	5000	196.9	5000	196.9
19 Recommended Clearance Height*	5000	196.9	5000	196.9

* Clearance dimensions are for reference only.

** Measurement taken with tailgate down for ejector body.

Gradeability/Speed/Rimpull

To determine gradeability performance: Read from gross weight down to the percent of total resistance. Total resistance equals actual percent grade plus rolling resistance as a general guide use 2% for rolling resistance in underground application or refer to the Caterpillar Performance Handbook. From the total resistance point, read horizontally to the curve with the highest obtainable gear, then down to maximum speed. Usable rimpull will depend upon traction available and weight on drive wheels.

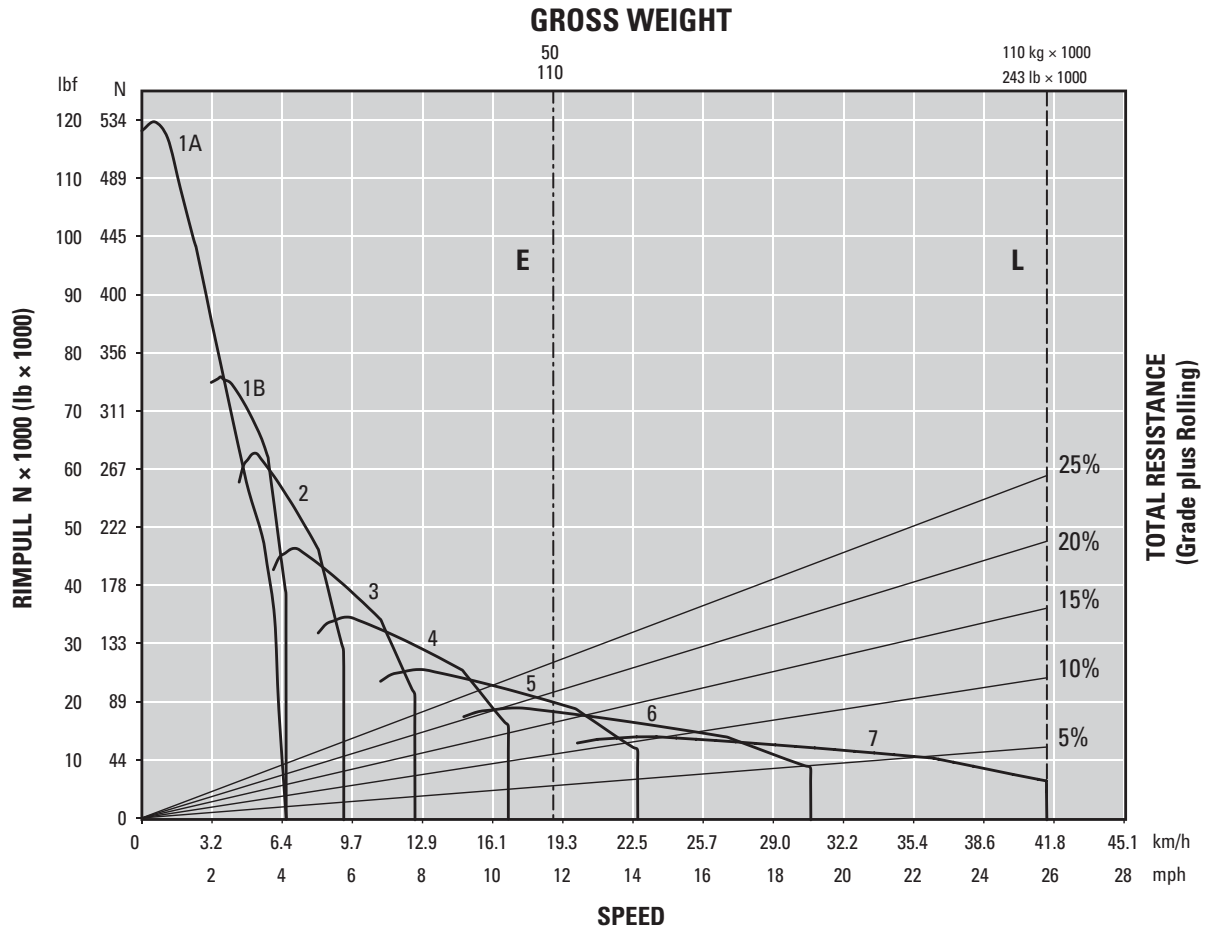

KEY

- 1A – 1st Gear (Converter Drive)
- 1B – 1st Gear
- 2 – 2nd Gear
- 3 – 3rd Gear
- 4 – 4th Gear
- 5 – 5th Gear
- 6 – 6th Gear
- 7 – 7th Gear

KEY

- E – Empty 50 000 kg (110,231 lb)
- L – Loaded 110 000 kg (242,509 lb)

Standard Equipment

Standard equipment may vary. Consult your Cat dealer for details.

ELECTRICAL

- Alarm, back-up
- Alternator, 95 amp
- Batteries, maintenance free
- Battery disconnect switch-ground level
- Brake and tail lights
- Corrosive protection spray
- Engine shutdown switch
- Headlights with dimmer switch
- Hydraulic tank low level sensor
- Jump start receptacle
- Rear work light (cab mounted)
- Reversing lights
- Starting and charging system (24-volt)

OPERATOR ENVIRONMENT

- Brake drag indicator
- Cab pressurizer
- Cat Comfort TLV2 air suspension seat
- Cat Electronic Monitoring System (Cat EMS)
- Diagnostic connector
- Operator Present System
- Rearview mirrors
- Radio ready
- ROPS/FOPS cab with air conditioning
- Storage compartment
- Tilt/telescopic steering wheel
- Trainer/passenger seat and seat belt
- Turn signal indicators
- Windshield wiper and washer

POWER TRAIN

- All wheel oil cooled disc brakes
- Automatic retarder control
- Auto shift transmission
 - 7 speed forward/1 speed reverse
- Control throttle shifting
- 12 cylinder C27 ACERT ATAAC diesel engine
- Long life coolant
- Parking brakes (four wheels)
- Programmable gear blockout with body up
- Programmable ground speed limiting
- Torque converter with automatic lockup

OTHER STANDARD EQUIPMENT

- Articulated and oscillated hitch
- Belly guards
- Body up alarm
- Centralized lubrication points
- Dump body (26.9 m³ – 35.2 yd³)
- Exhaust catalytic converter/muffler
- Exhaust covers
- Firewall
- Frame lifting lugs
- Front and rear tow pin
- Front axle suspension
- Front rubber bumpers
- Oil sample adapters
- Remote transmission hydraulic oil cooler
- Secondary Steering System
- Tires – 35/65 R33 VSNT radial tires
- TPMS (Truck Payload Measurement System)
- TPMS remote display payload indicator
- Ventilated hood and covers
- VIMS Guardian 3rd generation

Optional Equipment

Optional equipment may vary. Consult your Cat dealer for details.

- Bodies
 - Body impact liners, heavy duty
 - Body wear liners, heavy duty
 - Dump – 32.6 m³ (42.6 yd³)
 - Dump – 33.8 m³ (44.2 yd³)
 - Dump – 36.6 m³ (47.9 yd³)
 - Ejector – 26.9 m³ (35.2 yd³)
 - Ejector – 29.4 m³ (38.5 yd³)
- Color camera and monitoring system
- Engine shutdown on fire system activation
- Fast fill system
 - Coolant
 - Engine
 - Fuel
 - Hydraulic
 - Transmission
- Fire extinguisher, hand held
- ID numbers for rims
- Idle timer
- Electrical isolation switches
- Onboard fire suppression system, 65L
- Retractable visor group
- Seat covers
- Spare rim

AD60 Underground Articulated Truck

For more complete information on Cat products, dealer services, and industry solutions, visit us on the web at www.cat.com

© 2012 Caterpillar Inc.
All rights reserved

Materials and specifications are subject to change without notice. Featured machines in photos may include additional equipment. See your Cat dealer for available options.

CAT, CATERPILLAR, SAFETY.CAT.COM, their respective logos, "Caterpillar Yellow" and the "Power Edge" trade dress, as well as corporate and product identity used herein, are trademarks of Caterpillar and may not be used without permission.

AEHQ6808 (08-2012)

