

R1700G

Underground Mining Loader



Engine

Engine Model	Cat® C11 ACERT™
Gross Power – SAE J1995 (1st-3rd gear/4th gear)	241/263 kW 323/353 hp
Net Power – SAE J1349 (1st-3rd gear/4th gear)	218/241 kW 293/323 hp

Operating Specifications

Nominal Payload Capacity – Trimming	14 000 kg	30,865 lb
	– Truck Loading	12 500 kg
Gross Machine Operating Weight	52 500 kg	115,745 lb

Bucket Capacities

Bucket Capacity	4.6-8.8 m ³	6.0-11.5 yd ³
-----------------	------------------------	--------------------------

R1700G Features

One Supplier

Caterpillar designed and manufactured major power and drive train components for reliability and performance.

Reliable and Durable Engine

The Cat® C11 engine offers the perfect balance between power, robust design and economy.

Power Shift Transmission

Reliable and rugged design to deliver power and efficiency for peak power train performance.

Hydraulics

Perfect balance between low effort controls and powerful hydraulics for smooth and fast cycle time.

Durable Structures

The heavy duty frame is designed and built to absorb twisting, impact and high loading forces for maximum durability and reliability.

Comfortable Cab

Ergonomically designed for all-day comfort, control and productivity.

Aggressive Bucket Design

Engineered for optimal loadability and life in tough mining application. Various sizes and configurations available to match material and mine conditions.

Enhanced Serviceability

Designed with improved service points and grouped service locations to simplify maintenance and repair.

Built in Safety

Safety is not an after thought, but an integral part of all machine and system design.

Contents

Power Train – Engine	3
Power Train – Transmission	4
Hydraulics	5
Structures.....	6
Operator Comfort	7
Buckets.....	8
Serviceability	9
Customer Support.....	10
Safety	11
R1700G Underground Mining Loader Specifications.....	12
R1700G Standard Equipment.....	16
R1700G Optional Equipment	17



The R1700G underground loader is designed for high production, low cost-per-ton loading and tramming in underground mining applications. Compact design with agile performance, rugged construction and simplified maintenance ensures excellent productivity, long life and low operating costs.

Engineered for performance, designed for comfort, built to last.

Power Train – Engine

The Cat® C11 engine is built for power, reliability and efficiency.

Engine

The Cat® C11 engine with ACERT™ Technology is U.S. EPA Tier 3 and EU Stage III compliant. It features efficient fuel management for quick response, high productivity and exceptional service life. A new, sculptured cylinder block provides greater strength and lighter weight.

High Torque Rise

Provides unequalled lugging force while digging, tramming and traversing steep grades. Torque rise effectively matches transmission shift points for maximum efficiency and fast cycle times.

Radiator

Modular radiator with swing-out grill provides easy access for cleaning or repair. Built in sight gauge allows for quick, safe coolant level checks.

Pistons

Oil cooled pistons increase heat dissipation and promote longer piston life.

ADEM™ IV System

Controls the fuel injector solenoids and monitors fuel injection. This system provides automatic altitude compensation and air filter restriction indication.

Turbocharged and Aftercooled

Air-to-air aftercooling provides improved fuel economy by packing cooler, denser air into cylinders for more complete combustion of fuel and lower emissions.

Electronic Unit Injection (EUI)

Proven high-pressure, direct injection fuel system electronically monitors operator demands and sensor inputs to optimize engine performance.

Design Construction

Caterpillar designed one-piece cast iron block provides maximum strength and durability.

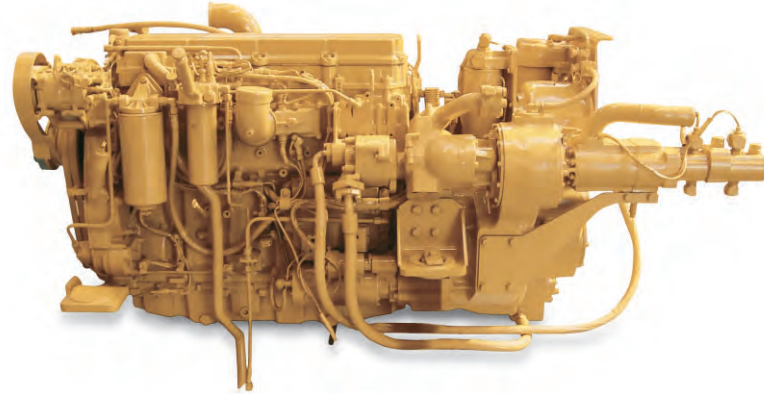

Power Train – Transmission

More power to the ground for greater productivity.

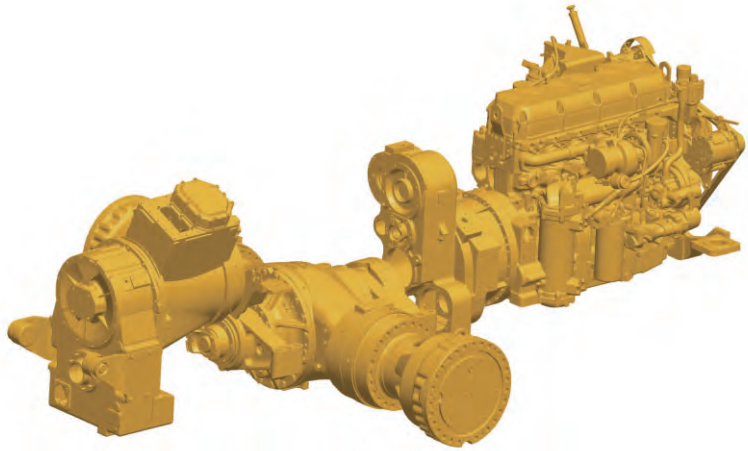

Power Shift Transmission

The Cat four-speed planetary power shift transmission is matched with the Cat® C11 engine to deliver constant power over a wide range of operating speeds.

Robust Design

Designed for rugged underground mining conditions, the proven planetary power shift transmission is built for long life between overhauls.

Torque Converter

High capacity torque converter delivers more power to the wheels for superior power train efficiency.

Electronic Autoshift Transmission

The electronic auto shift transmission increases operator efficiency and optimizes machine performance. The operator can choose between manual or auto shift modes.

Transmission Neutralizer

Using the left brake pedal, the operator can engage the service brakes and neutralize the transmission, maintaining high engine rpm for full hydraulic flow, enhancing digging and loading functions.

Final Drives

Cat final drives work as a system with the planetary power shift transmission to deliver maximum power to the ground. Built to withstand the forces of high torque and impact loads, double reduction final drives provide high torque multiplication to further reduce drive train stress.

Axles

Heavy duty axles are built rugged for long-life in the most demanding environments.

Oscillating Rear Axle

Oscillating rear axle ensures four-wheel ground contact for maximum traction and stability at all times.

Differential

No spin rear differential reduces tire wear and maximizes traction in uneven terrain.

Brakes

Fully enclosed oil immersed disc brakes incorporate independent service and parking brake pistons. Hydraulic actuated independent circuits provide improved performance and reliability.



Hydraulics

Cat hydraulics deliver the power and control to keep material moving.

Hydraulic System

Powerful Cat hydraulics deliver exceptional digging and lifting forces and fast cycle times.

Lift and Tilt System

High hydraulic flow rates provide fast hydraulic cylinder response and powerful lift forces. Large-bore tilt and lift cylinders deliver exceptional strength, performance and durability.

Pilot Controls

Low effort, pilot operated joystick implement control with simultaneous lift and tilt functions optimizes operating efficiency. Optional hydraulic controls enable an ejector bucket to be controlled from a switch on the bucket control joystick.

Steering System

STIC™ control system integrates steering and transmission functions into a single controller for maximum responsiveness and smooth control.

Optional Ride Control

The optional ride control system uses a nitrogen filled oil accumulator in the hydraulic lift circuit to act as a shock absorber for the bucket and lift arms. The lift arm and bucket response to movement is dampened over rough ground, reducing fore and aft pitch, improving cycle times and load retention. A smoother, more comfortable ride gives operators the confidence to travel at higher speeds during load and carry operations.

Cat Hydraulic Hose

Field proven Cat high pressure XT™ hydraulic hoses are exceptionally strong and flexible for maximum system reliability and long life in the most demanding conditions. Reusable couplings with O-ring face seals provide superior, leak free performance and prolong hose assembly life.

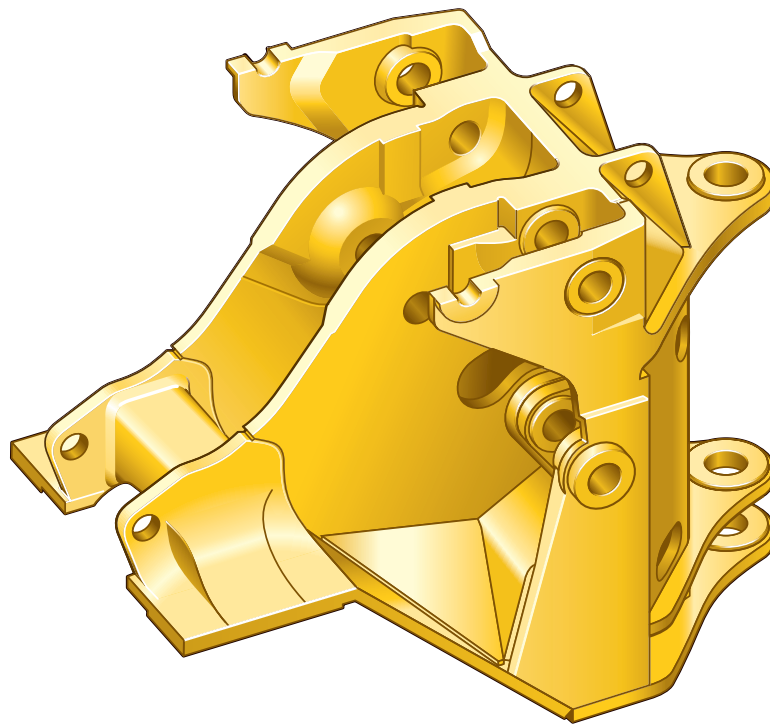

Structures

Rugged Cat structures – the backbone of the R1700G's durability.

Frame Design

The frame is engineered to withstand extreme forces generated during loading and tramming cycles. A precision manufacturing process ensures all structures are consistently built to high quality. Deep penetration and consistent welds throughout the frame ensures structures are solidly fused to provide a sturdy platform for the linkage and the axles. The design and manufacturing quality of Cat LHD frames have been proven by our customers, many of whom reuse frames during machine rebuilds to get 2nd and 3rd lives out of their LHD's.

Z-Bar Loader Linkage

Proven Z-Bar loader linkage geometry generates powerful breakout force and an increased rack back angle for better bucket loading and material retention. Heavy duty steel lift arms with cast steel cross tube ensures extreme loads encountered during loading and tramming are efficiently dissipated for long service life.

Sealed Pins

Sealed colleted pins are fitted to all bucket and lift arm hinge points for longer pin and bushing life. This reduces maintenance costs and extends service intervals. The sealed joints retain lubrication and prevent contaminant entry.

Hitch

Spread hitch design widens the distance between upper and lower hitch plates to distribute forces and increase bearing life. Thicker hitch plates reduce deflection. The wide opening provides easy service access. Upper and lower hitch pins pivot on roller bearings to distribute horizontal and vertical loads over a greater surface area. Shim adjusted preload reduces maintenance time. An on-board steering frame lock pin is fitted to prevent articulation during maintenance and service.

Operator Comfort

Ergonomically designed for all-day comfort, control and productivity.

The operator station is ergonomically designed for total machine control in a comfortable, productive and safe environment. All controls, levers, switches and gauges are positioned to maximize productivity and minimize operator fatigue.

Protective Structure

Integral to the cab and frame, the Rollover Protective Structure (ROPS) and the Falling Objects Protective Structure (FOPS), are resiliently mounted to the frame to isolate the operator from vibration for a more comfortable ride.

Optional Enclosed Cab

Optional sound-suppressed ROPS cab provides a quiet, secure working environment. Large window openings offer excellent visibility in all directions. Enclosed design provides fresh, pressurized, temperature-controlled air circulation for a more comfortable working environment.

STIC™ Steering and Transmission Integrated Control

STIC™ provides effortless control of the machine by a single controller. Simple side-to-side motion articulates the machine. Directional shifting (forward/neutral/reverse) is controlled using a three position rocker switch. The thumb operated buttons control gear selection.

Dual-Pedal Braking

Dual brake pedals function as a brake and a transmission neutralizer so the operator can maintain high engine rpm for full hydraulic flow and fast cycle times.

Monitoring System

Cat® Electronic Monitoring System (Cat EMS) continuously provides critical machine data to keep the machine performing at top production levels.

- **Message Center.** Three-category warning system alerts operator of abnormal machine health conditions.
- **Gauge Cluster.** Maintains a constant display of vital machine functions.
- **Speedometer/Tachometer Module.** Monitors three systems: engine speed, ground speed and gear indicator.

Pilot Controls

Low-effort pilot operated joystick controls integrate steering, transmission and implement functions for smoother, faster cycles with less operator fatigue.

Suspension Seat

Ergonomic, fully adjustable suspension seat provides optimal operator comfort. Thick cushions reduce pressure on the operator's lower back and thighs. Wide, retractable seat belts provide a secure, comfortable restraint.



Buckets

Rugged performance and reliability in tough underground mining applications.



Buckets

Aggressive Cat bucket designs deliver unmatched productivity in the most demanding applications. Underground mining buckets are designed for optimal loadability and structural reliability to increase productivity and help lower your cost-per-ton.

Bucket Selection

Cat underground loader buckets are available in standard and high penetration configurations to meet a range of loading, hauling and dumping conditions.

Bucket Capacities

Buckets are available in a range of sizes and capacities to suit most material types and densities.

Wear Packages

Weld-on wear plates in high wear areas are standard. Additional wear packages are available, including sacrificial wear strips and Cat heel shrouds, protect the edges from damage for longer bucket life and reduce the need for costly bucket rebuilds.

Cutting Edges

Cat half arrow and cast half arrow cutting edges extend bucket life in high wear applications.





Serviceability

More time for production.

Service Access

Easy access to daily service points simplifies servicing and reduces time spent on regular maintenance procedures.

Ground-Level Access

Allows convenient servicing to all tanks, filters, lubrication points and compartment drains.

Air Filters

Radial seal air filters are easy to change, reducing time required for air filter maintenance.

Sight Gauges

Fluid level checks are made easier with sight gauges.

Diagnostics

Cat Electronic Technician (Cat ET) service tool enables quick electronic diagnosis of machine performance and key diagnostic data for effective maintenance and repairs.

Sealed Electrical Connectors

Electrical connectors are sealed to lock out dust and moisture. Harnesses are covered for protection. Wires are color and number coded for easy diagnosis and repair.

Scheduled Oil Sampling

S-O-SSM helps avoid minor repairs becoming major ones.

Customer Support

Cat® dealer services keep underground mining equipment productive.



Cat dealers offer solutions, services and products that help lower costs, enhance productivity and manage your operation efficiently. From the selection of Cat equipment until the day you rebuild, trade or sell it, the support you get from your Cat dealer makes the difference that counts.

Dealer Capability

Cat dealers will provide the level of support you need, on a global scale. Dealer expert technicians have the knowledge, experience, training and tooling to handle your repair and maintenance needs, when and where you need them.

Product Support

When Cat products reach the field, they are supported 24/7 by a worldwide network of reliable and prompt parts distribution facilities, dealer service centers, and technical training facilities to keep your equipment up and running.

Service Support

Cat equipment is designed and built to provide maximum productivity and operating economy throughout its working life. Cat dealers offer a wide range of service plans that will maximize return on your investment, including:

- Preventive Maintenance Programs
- Diagnostic Programs, such as Scheduled Oil Sampling and Technical Analysis
- Rebuild and Reman Options
- Customer Support Agreements

Technology Products

Cat dealers offer a range of advanced technology products designed to improve efficiency, productivity and lower costs.

Operator Training

Today's complex products require operators have a thorough understanding of machine systems and operating techniques to maximize efficiency and profitability. Your Cat dealer can arrange training to improve productivity, decrease downtime, reduce operating costs, enhance safety, and improve your return on investment.

Application Awareness

Application and site-specific factors, such as: material density, loading position, grades, speeds, and haul road design influence operating and maintenance costs. Your Cat dealer can provide you with the understanding to optimize productivity and the total cost of ownership.

www.cat.com

For more complete information on Cat products, dealer services, and industry solutions, visit us on the web at www.cat.com.



Safety

Designed with safety as the first priority.

Product Safety

Caterpillar has been and continues to be proactive in developing mining machines that meet or exceed safety standards. Safety is an integral part of all machine and systems designs.

Engine Shut Off Switch

A secondary engine shutoff switch is located at ground level.

Integral ROPS Cab

Integral to the cab and frame, the ROPS is resiliently mounted to the frame to isolate the operator from vibration for a more comfortable ride.

Brake Systems

Four corner oil-cooled braking system provides excellent control. The service brake system is actuated by modulated hydraulic pressure, while the parking brake function is spring applied and hydraulic released. This system assures braking in the event of loss of hydraulic pressure.

Standard Safety Features

Anti-skid upper deck surfaces, ground level compartment sight gauges, increased visibility, 3-point access to cab and machine, push out safety glass, suspension seat, inertia reel retractable seat belt, lift arm support pins, hot and cold side of engine, steering frame lock, hinged belly guards.

SAFETY.CAT.COM™

For more complete information on safety, please visit <http://safety.cat.com>.

R1700G Underground Mining Loader Specifications

Engine

Engine Model	Cat® C11 ACERT™	
Rated Power	1,800 rpm	
Gross Power – SAE J1995	241/263 kW	323/353 hp
Net Power – SAE J1349	218/241 kW	293/323 hp
Net Power – ISO 9249	218/241 kW	293/323 hp
Net Power – 80/1269/EEC	218/241 kW	293/323 hp
Bore	130 mm	5.1 in
Stroke	140 mm	5.5 in
Displacement	11.1 L	680 in ³

- Power ratings apply at a rated speed of 1,800 rpm when tested under the reference conditions for the specified standard.
- Ratings based on SAE J1995 standard air conditions of 25° C (77° F) and 100 kPa (29.61 Hg) barometer. Power based on fuel having API gravity of 35 at 16° C (60° F) and an LHV of 42 780 kJ/kg (18,390 BTU/lb) when engine used at 30° C (86° F).
- Engine derate will commence at an altitude of 3050 m (10,006 ft).
- Compliant with U.S. Environmental Protection Agency Tier 3 emissions standards.

Operating Specifications

Nominal Payload Capacity	12 500 kg	27,558 lb
Nominal Payload Capacity – Trimming	14 000 kg	30,865 lb
Nominal Payload Capacity – Truck Loading	12 500 kg	27,558 lb
Gross Machine Operating Weight	52 500 kg	115,745 lb
Static Tipping Load Straight Ahead Lift Arms Horizontal	31 781 kg	70,065 lb
Static Tipping Load Full Turn Lift Arms Horizontal	26 306 kg	57,995 lb
Breakout Force (SAE)	20 885 kg	46,051 lb

Weights

Empty	38 500 kg	84,878 lb
Front Axle	16 940 kg	37,346 lb
Rear Axle	21 560 kg	47,532 lb
Loaded	51 000 kg	112,436 lb
Front Axle	37 077 kg	81,741 lb
Rear Axle	13 923 kg	30,695 lb
Loaded – Trimming	52 500 kg	115,743 lb

Transmission

Forward 1	4.7 km/h	2.9 mph
Forward 2	8.3 km/h	5.2 mph
Forward 3	14.3 km/h	8.9 mph
Forward 4	24.1 km/h	15 mph
Reverse 1	5.4 km/h	3.3 mph
Reverse 2	9.4 km/h	5.8 mph
Reverse 3	16.4 km/h	10.2 mph
Reverse 4	25.3 km/h	15.7 mph

Hydraulic Cycle Time

Raise	6.8 Seconds
Dump	2.9 Seconds
Lower, empty, float down	2.4 Seconds
Total Cycle Time	12.1 Seconds

Bucket Capacities

Dump Bucket – 1	4.6 m ³	6 yd ³
Dump Bucket – 2	5 m ³	6.5 yd ³
Dump Bucket – 3 (Standard Bucket)	5.7 m ³	7.5 yd ³
Dump Bucket – 4	6.6 m ³	8.6 yd ³
Dump Bucket – 5	7.3 m ³	9.5 yd ³
Dump Bucket – 6	8.8 m ³	11.5 yd ³
Ejector Bucket	5.6 m ³	7.3 yd ³

Turning Dimensions

Outside Clearance Radius**	6878 mm	270.8 in
Inner Clearance Radius**	3229 mm	127.1 in
Axle Oscillation	8°	
Articulation Angle	44°	

** Note: Clearance Dimensions are for reference only.

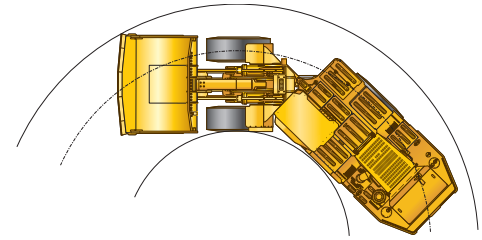

Tires

Tire Size	26.5 × 25 36 PLY STMS L5S
-----------	---------------------------

Service Refill Capacities

Engine Crankcase with Filter	34 L	8.98 gal
Transmission	47 L	12.4 gal
Hydraulic Tank	125 L	33 gal
Cooling System	63 L	16.6 gal
Front Differential and Final Drives	61 L	16.1 gal
Rear Differential and Final Drives	61 L	16.1 gal
Front Differential and Final Drives (With Axle Oil Cooler)	90 L	23.8 gal
Rear Differential and Final Drives (With Axle Oil Cooler)	90 L	23.8 gal
Fuel Tank	570 L	150.5 gal
Secondary Fuel Tank (If Equipped)	420 L	111 gal

Standards

Brakes	ISO 3450, AS2958.1, CAN-CSA424.30-M90
Cab/FOPS	BS EN ISO 3449, SAE J231, AS2294.3
Cab/ROPS	ISO 3471, SAE J1040, AS2294.2, EN13510

Dimensions

All dimensions are approximate.

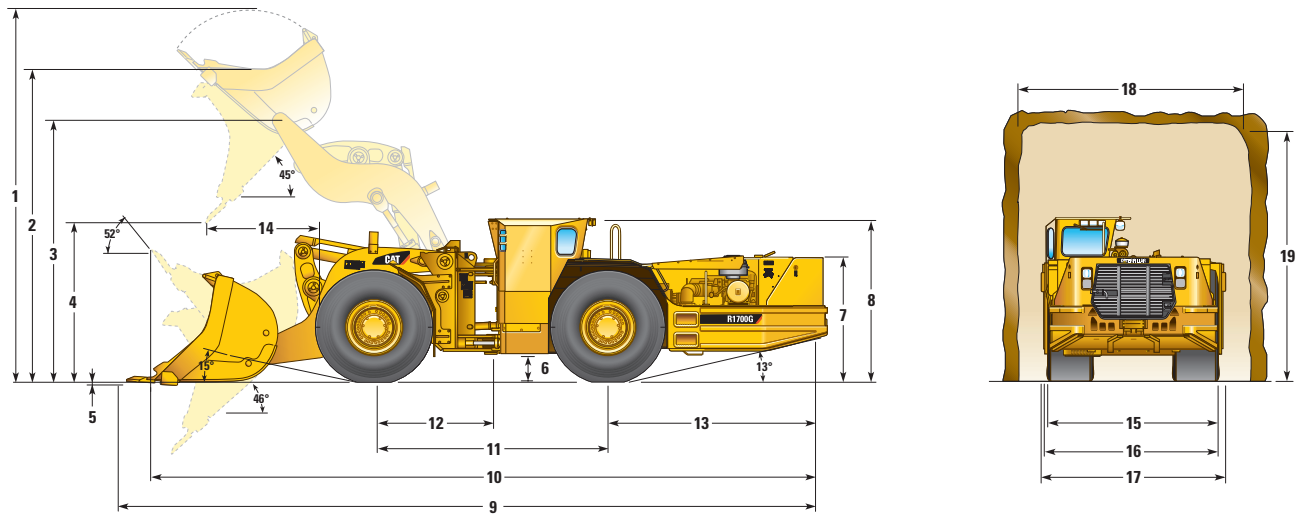

	256-0862		255-9970		252-7194		226-5404	
	Dump Bucket	Dump Bucket	Dump Bucket	Dump Bucket	Dump Bucket	Dump Bucket	Dump Bucket	Dump Bucket
Bucket Capacity	4.6 m ³	6.0 yd ³	5.0 m ³	6.5 yd ³	5.7 m ³	7.5 yd ³	6.6 m ³	8.6 yd ³
	mm	in	mm	in	mm	in	mm	in
Bucket Width over Cutting Edge	2672	105.2	2672	105.2	2772	109.1	2932	115.4
1 Height – Bucket Raised	5511	217.0	5511	217.0	5606	220.7	5680	223.6
2 Height – Max Dump	4899	192.9	4899	192.9	4899	192.9	4899	192.9
3 Height – Max Lift Bucket Pin	4104	161.6	4104	161.6	4104	161.6	4104	161.6
4 Height – Dump Clearance at Max Lift	2648	104.3	2524	99.4	2443	96.2	2392	94.2
5 Height – Digging Depth	5	0.2	15	0.6	20	0.8	26	1.0
6 Height – Ground Clearance	429	16.9	429	16.9	429	16.9	429	16.9
7 Height – Top of Hood	1968	77.5	1968	77.5	1968	77.5	1968	77.5
8 Height – Top of ROPS	2557	100.7	2557	100.7	2557	100.7	2557	100.7
9 Length – Overall (Digging)	10 746	423.1	10 915	429.7	11 035	434.4	11 105	437.2
10 Length – Overall (Tramming)	10 447	411.3	10 549	415.3	10 589	416.9	10 663	419.8
11 Length – Wheelbase	3680	144.9	3680	144.9	3680	144.9	3680	144.9
12 Length – Front Axle to Hitch	1840	72.4	1840	72.4	1840	72.4	1840	72.4
13 Length – Rear Axle to Bumper	3439	135.4	3439	135.4	3439	135.4	3439	135.4
14 Length – Reach	1526	60.1	1639	64.5	1741	68.5	1768	69.6
15 Width – Overall Tire	2650	104.3	2650	104.3	2650	104.3	2650	104.3
16 Width – Machine with Bucket	2790	109.8	2790	109.8	2894	113.9	3050	120.1
17 Width – Machine without Bucket	2689	105.9	2689	105.9	2689	105.9	2689	105.9
18 Recommended Clearance Width	4000	157.5	4000	157.5	4000	157.5	4000	157.5
19 Recommended Clearance Height	4000	157.5	4000	157.5	4000	157.5	4000	157.5

R1700G Underground Mining Loader Specifications

Dimensions

All dimensions are approximate.

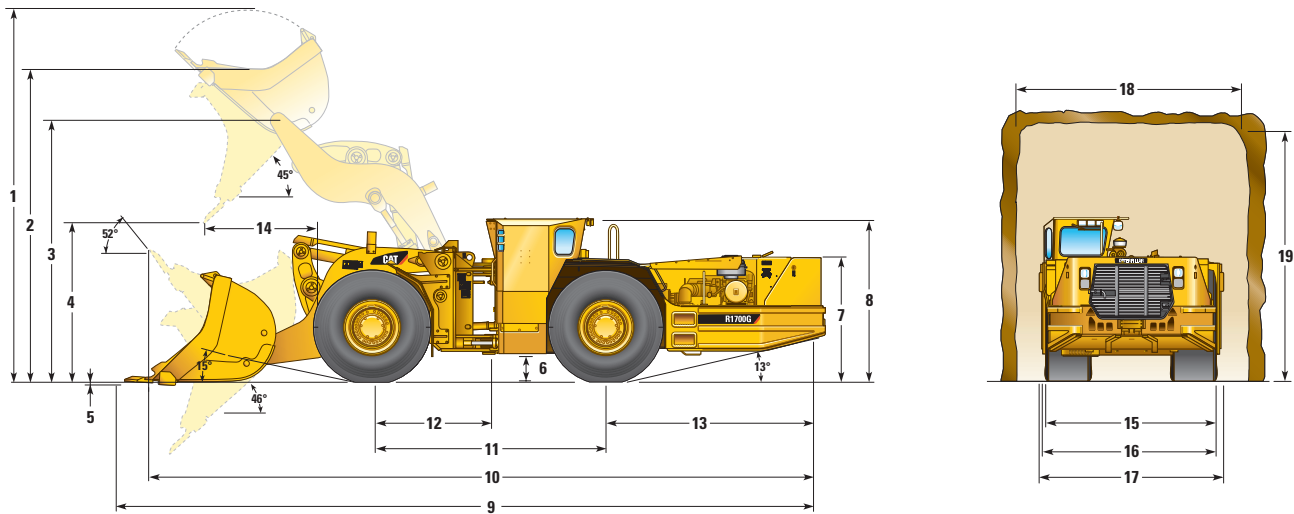

	256-0356		256-0386		281-0445	
	Dump Bucket	Dump Bucket	Dump Bucket	Dump Bucket	Ejector Bucket	Ejector Bucket
Bucket Capacity	7.3 m ³	9.5 yd ³	8.8 m ³	11.5 yd ³	5.6 m ³	7.3 yd ³
	mm	in	mm	in	mm	in
Bucket Width over Cutting Edge	2982	117.4	3492	137.5	2780	109.4
1 Height – Bucket Raised	5751	226.4	5751	226.4	5858	230.6
2 Height – Max Dump	4899	192.9	4899	192.9	4913	193.4
3 Height – Max Lift Bucket Pin	4104	161.6	4104	161.6	4104	161.6
4 Height – Dump Clearance at Max Lift	2320	91.3	2320	91.3	2352	92.6
5 Height – Digging Depth	33	1.3	33	1.3	76	3.0
6 Height – Ground Clearance	429	16.9	429	16.9	429	16.9
7 Height – Top of Hood	1968	77.5	1968	77.5	1968	77.5
8 Height – Top of ROPS	2557	100.7	2557	100.7	2557	100.7
9 Length – Overall (Digging)	11 207	441.2	11 207	441.2	11 132	438.3
10 Length – Overall (Tramming)	10 724	422.2	10 724	422.2	10 706	421.5
11 Length – Wheelbase	3680	144.9	3680	144.9	3680	144.9
12 Length – Front Axle to Hitch	1840	72.4	1840	72.4	1840	72.4
13 Length – Rear Axle to Bumper	3439	135.4	3439	135.4	3439	135.4
14 Length – Reach	1836	72.3	1836	72.3	1738	68.4
15 Width – Overall Tire	2650	104.3	2650	104.3	2650	104.3
16 Width – Machine with Bucket	3104	122.2	3610	142.1	2902	114.3
17 Width – Machine without Bucket	2689	105.9	2689	105.9	2689	105.9
18 Recommended Clearance Width	4000	157.5	4000	157.5	4000	157.5
19 Recommended Clearance Height	4000	157.5	4000	157.5	4000	157.5

Gradeability/Speed/Rimpull

To determine gradeability performance: Read from gross weight down to the percent of total resistance. Total resistance equals actual percent grade plus rolling resistance. As a general guide use 2% for rolling resistance in underground application or refer to the Caterpillar Performance Handbook. From the total resistance point, read horizontally to the curve with the highest obtainable gear, then down to maximum speed. Usable rimpull will depend upon traction available and weight on drive wheels.

- - - - - Typical Field Empty Weight
 Loaded Weight

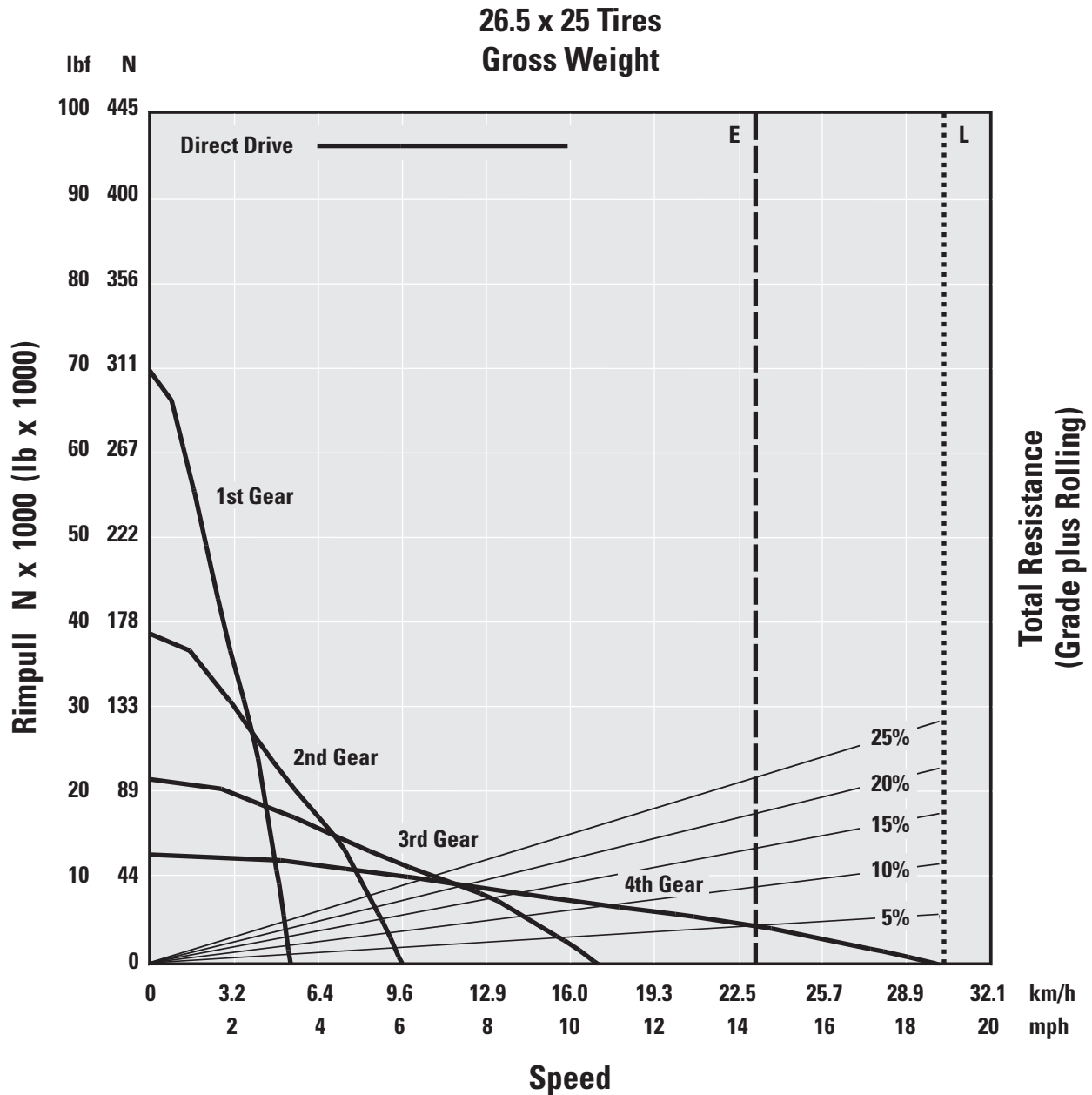

E - Empty 38 500 kg (84,878 lb)
 L - Loaded 51 000 kg (112,436 lb)

R1700G Standard Equipment

Standard equipment may vary. Consult your Cat dealer for details.

ELECTRICAL

Alternator, 95-amp
Battery Disconnect Switch, Ground Level
Corrosive Protection Spray
Diagnostic Connector
Electric Starting, 24-volt
Engine Shutdown Switch
External Lighting System, Front, Rear
Low Maintenance Batteries
Reversing Alarm
Starting and Charging System

OPERATOR ENVIRONMENT

Cat Electronic Monitoring System (Cat EMS)
Electric Horns
Gauges
 Engine Coolant Temperature
 Fuel Level
 Hydraulic Oil Temperature
 Speedometer
 Tachometer
Pilot Hydraulic Implement Controls,
Single Joystick
ROPS/FOPS Structure
Suspension Seat With Retractable Seat Belt
STIC™ Steering

POWER TRAIN

Cat C11 ATAAC Diesel Engine with
ACERT™ Technology, 6-Cylinder
Long Life Coolant
SAFR™ Full Hydraulic Enclosed Wet
Multiple-Disc Brakes
Planetary Powershift Transmission with
Automatic Shift Control, 4 Speed Forward/
4 Speed Reverse
Engine Air Intake Precleaner
Torque Converter
Transmission Neutralizer
Fuel Priming Aid
Crossflow Radiator

OTHER STANDARD EQUIPMENT

Bucket Positioner, Return To Dig
Catalytic Exhaust Purifier/Muffler Group
Engine and Transmission Belly Guards
Fenders, Front, Rear
Firewall
Hardox 450 Bucket Lip
Rear Frame Protection Wear Bars
100 × 50 mm (4 × 2 in)
Semi Centralized Lubrication Points
Swing Out Radiator Grill
Tires, 26.5 × 25 36-Ply STMS L5S

Optional equipment may vary. Consult your Cat dealer for details.

Alternative Tire Arrangements

Automatic Lube System

Auxiliary Start Receptacle

Brake Light

Brake Pressure Gauges

Brake Release Arrangements

Bucket Heel Shrouds

Bucket Sacrificial Wear Strip Package

Centralized Lube System, Manual

Draw Bar Attachment, Bolt-on

Electronic Access Module

Enclosed Operators Station

Air Conditioning

Pressurizer

Dome Light

Radio Ready

Fast Fill System

Coolant

Engine

Fuel

Hydraulic

Transmission

Fire Extinguishers

Fire Suppression System

Front Light Protectors

Heater, Air Conditioning

Oil Sample Adapters

Payload Control System (PCS)

Remote Control Interface Kit

Reversible Steering

Ride Control System

Seat Covers

Secondary Steering System

Service Tools

Tee Seat

R1700G Underground Mining Loader

For more complete information on Cat products, dealer services, and industry solutions, visit us on the web at www.cat.com

© 2011 Caterpillar Inc.
All rights reserved

Materials and specifications are subject to change without notice. Featured machines in photos may include additional equipment. See your Cat dealer for available options.

CAT, CATERPILLAR, SAFETY.CAT.COM, their respective logos, "Caterpillar Yellow" and the "Power Edge" trade dress, as well as corporate and product identity used herein, are trademarks of Caterpillar and may not be used without permission.

AEHQ6387 (10-2011)
Replaces AEHQ5607-01

